

INSTRUCTION MANUAL - *GUIDE D'INSTALLATION*

B017

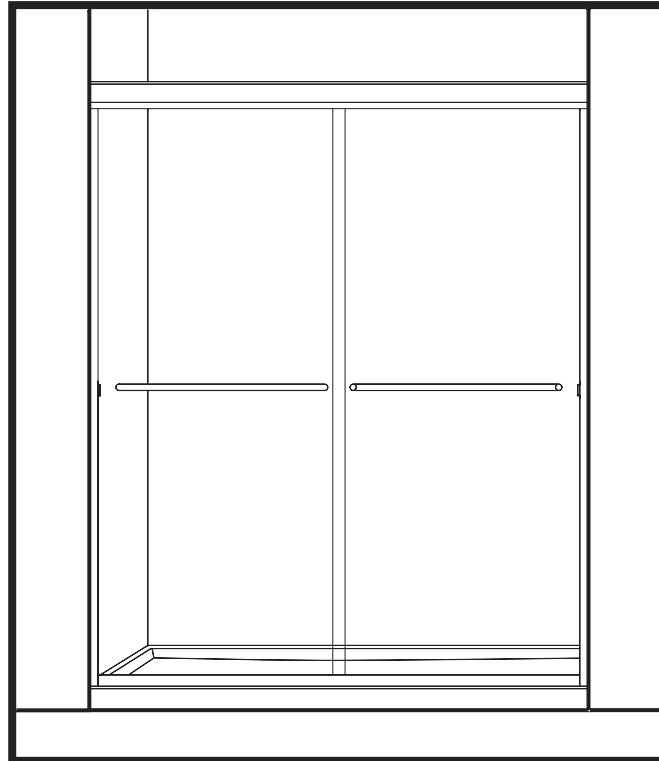

SHOWER / DOUCHE

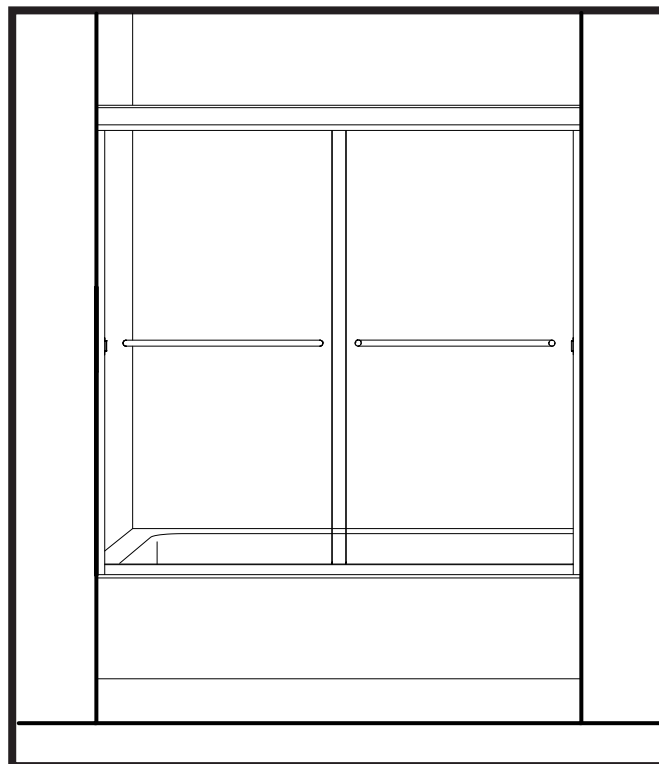

TUB / BAIGNOIRE

Please keep this manual and product code number for future reference and for ordering replacement parts if necessary.

Veillez conserver ce manuel et le code de produit pour des références futures, et au besoin, la commande de pièces de rechange.

GENERAL INSTRUCTIONS

- Read this manual carefully and completely before proceeding.
- It is recommended that you wear safety glasses at all times during the installation.

En

INSTALLATION OVER CERAMIC TILES

- If your shower door is to be installed over ceramic tiles, the tiles should lay completely under the wall jamb.
- Silicone should be used to seal the gap where the ceramic tiles meet the fixed panel.

NOTICE

- Caulking: no sealant is required inside the shower, unless otherwise stated.
- Some models are equipped with clear sealing gaskets.

CARE FOR YOUR SHOWER DOOR

- Never use scouring powder pads or sharp instruments on metal pieces or glass panels. An occasional wiping down with a mild soap diluted in water is all that is needed to keep the panels and aluminum parts looking new.
- We recommend wiping the glass panels with a squeegee after each use.

INSTRUCTIONS GÉNÉRALES

- Lire attentivement et complètement le manuel d'installation avant de procéder.
- Il est recommandé de porter des lunettes de sécurité en tout temps lors de l'installation.

Fr

INSTALLATION SUR LES TUILES EN CÉRAMIQUE

- Si votre porte de douche doit être installée sur une bordure en céramique, le jambage doit reposer complètement sur cette dernière.
- Le calfeutrage doit être appliqué sur le côté extérieur de la douche où le panneau fixe rencontre la bordure en céramique.

NOTE

- Calfeutrage: aucun scellant n'est nécessaire à l'intérieur de la douche.
- Certains modèles sont dotés de joints d'étanchéité clairs.

L'ENTRETIEN DE VOTRE DOUCHE

- Ne jamais utiliser de poudre ou de tampon à récurer, ni d'instrument tranchant sur les parties en métal ou en verre. De temps à autre, il suffit de nettoyer la porte avec une solution d'eau et un détergent doux pour conserver l'aspect neuf des panneaux de verre et du cadre en aluminium.
- Nous recommandons de passer une raclette de douche sur les panneaux de verre après chaque utilisation.

TOOLS AND MATERIAL REQUIRED / OUTILS ET MATÉRIAUX REQUIS

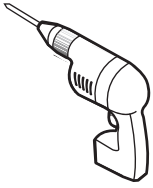

DRILL
PERCEUSE

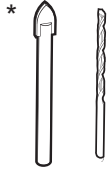

1/4" & 1/8" DRILL BITS
MÈCHE 1/4" & 1/8"



SCREWDRIVERS
TOURNEVIS

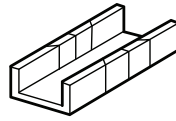

MITER BOX
BOÎTE À ONGLETS



WRENCH
CLÉ ANGLAISE



MASKING TAPE
RUBAN DE MASQUAGE

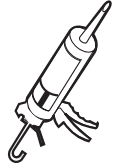

SILICONE
SCÉLLANT



PENCIL
CRAYON



TAPE MEASURE
RUBAN À MESURER



MALLET
MAILLET

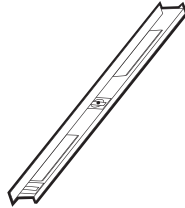

LEVEL
NIVEAU

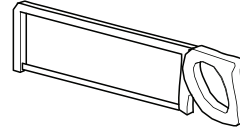

HACKSAW WITH 32 TEETH
PER INCH BLADE

SCIE À MÉTAUX AVEC 32 DENTS
PAR POUCE PAR LAME



SAFETY GLASSES
LUNETTES DE SÉCURITÉ

*** Use a 1/4" drill bit for ceramic when drilling into ceramic tiles**

* Utiliser une mèche de 1/4" destiné à céramique lors du perçage des tuiles en céramique.

DETECTING THE SEKUR SIDE ON THE GLASS / DÉTECTER LE CÔTÉ SEKUR SUR LE VERRE

The panels are treated differently on each side. Locate the SEKUR label that is installed on the **INTERIOR** side of the shower. Remove the sticker at the end of the installation.

*Les panneaux ont un traitement différent sur chaque côté. Localiser l'étiquette SEKUR qui est installée sur la face **INTÉRIEURE** de la douche. Retirer l'étiquette à la fin de l'installation.*

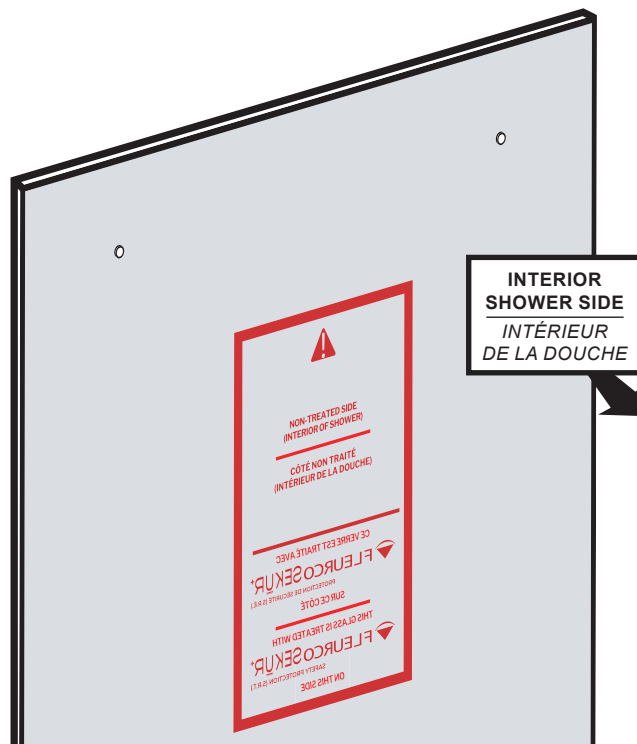

POSSIBLE CONFIGURATIONS / CONFIGURATIONS POSSIBLES

SHOWER / DOUCHE

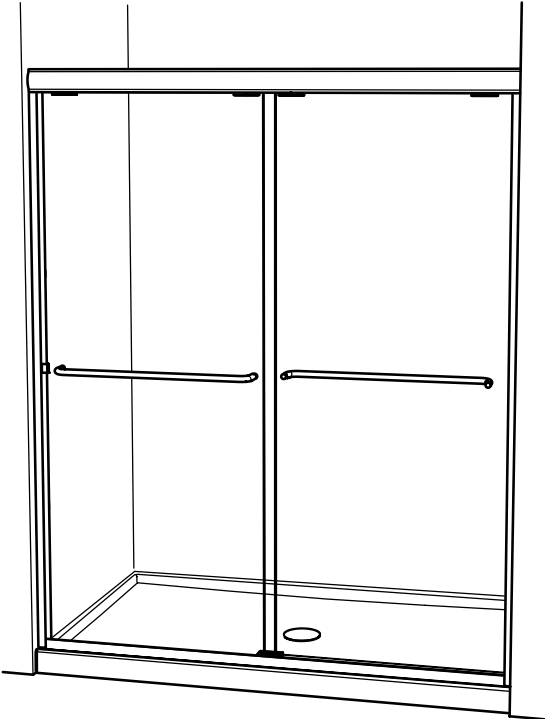

TUB / BAIN

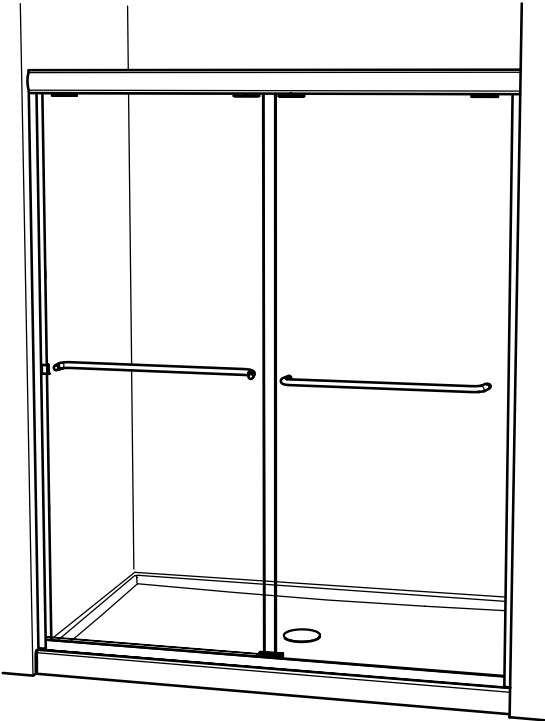
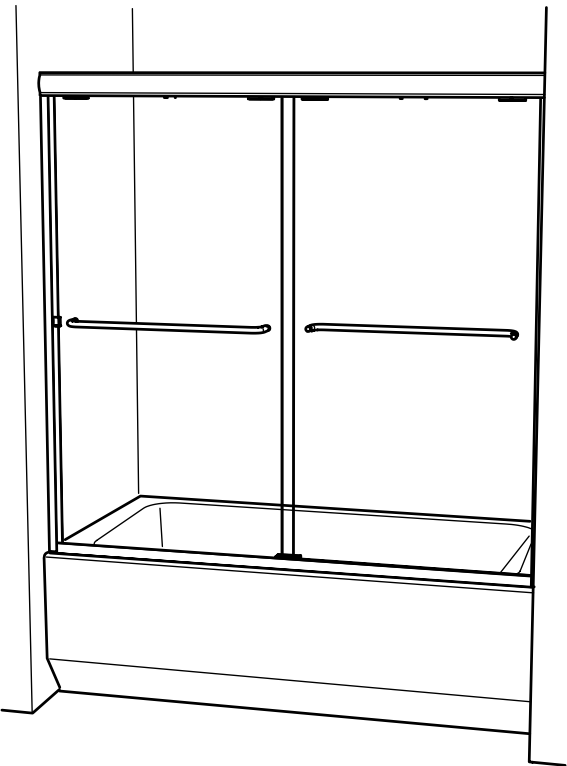

*

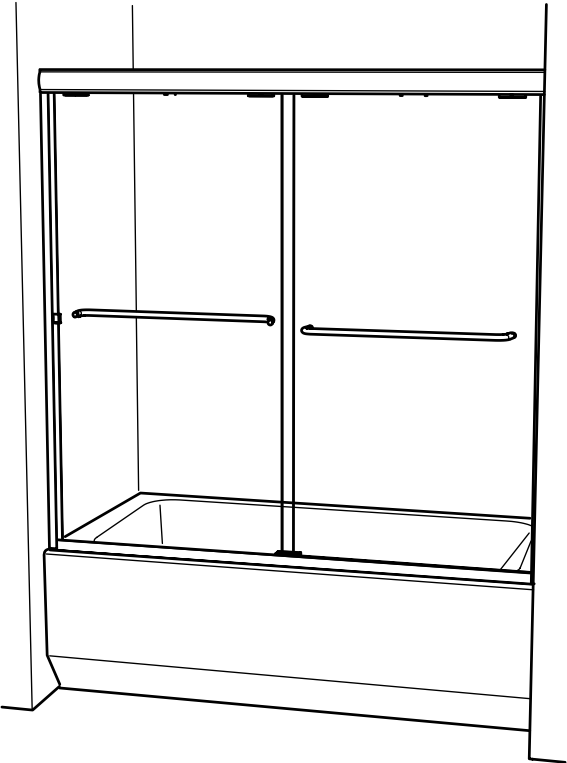

* This configuration is illustrated in this manual.
* Cette configuration est illustrée dans ce manuel.

PARTS LISTING / LISTE DES PIÈCES

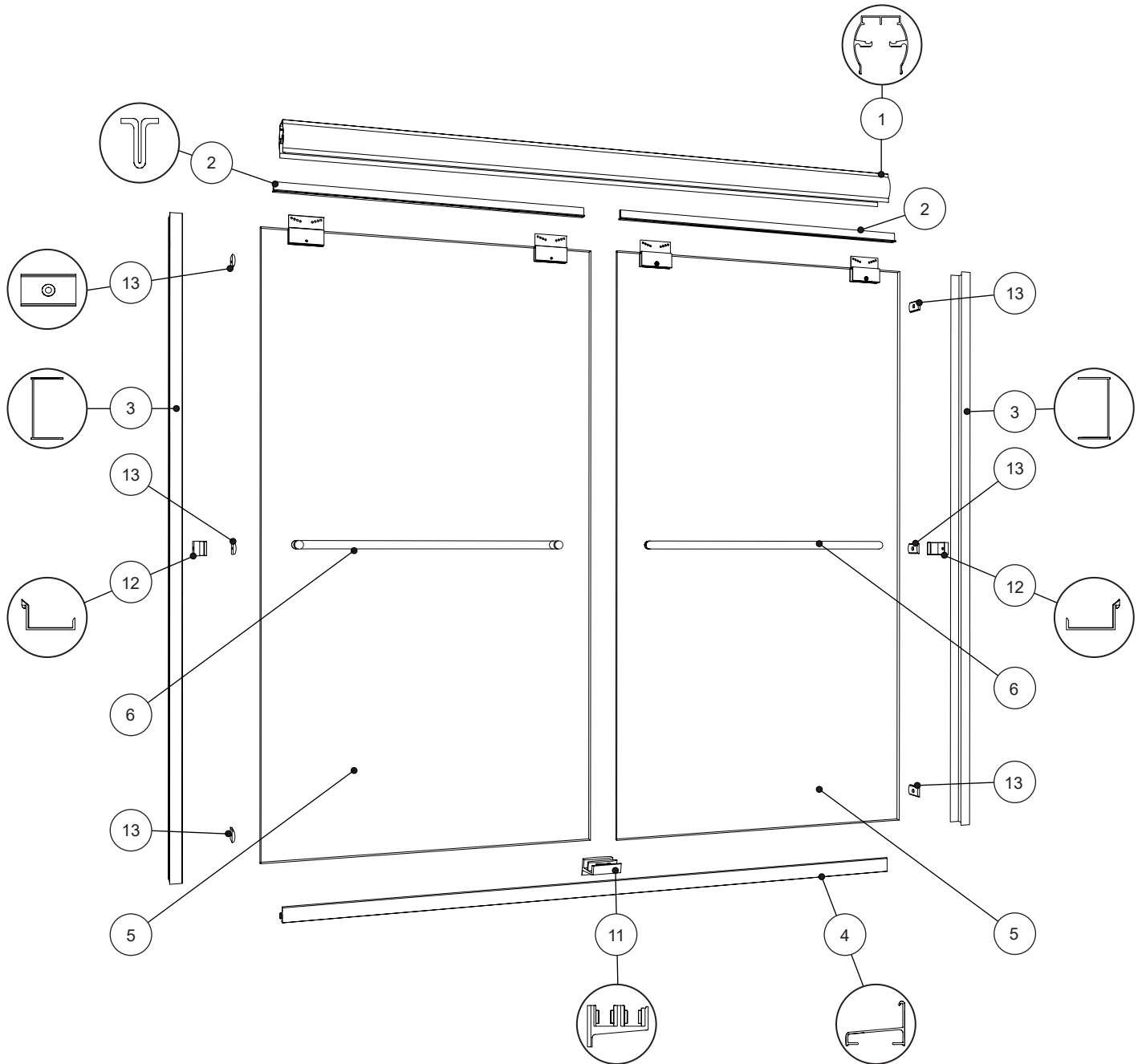

PARTS LISTING / LISTE DES PIÈCES

ITEM	PARTS LISTING / LISTE DES PIÈCES	QTY
1	TOP RAIL / RAIL SUPÉRIEUR	1
2	ANTI-JUMP / ANTI-SAUT	2
3	WALL JAMB / JAMBAGE	2
4	BOTTOM RAIL / RAIL INFÉRIEUR	1
5	GLASS PANEL / PANNEAU EN VERRE	2
6	HANDLE BAR / POIGNÉE	2
ITEM	HARDWARE LISTING / LISTE DE QUINCAILLERIE	QTY
7	WHEELS / ROUES	8
8	PAN HEAD MACHINE SCREW #8 - 3/8" / VIS PAN #8 - 3/8"	8
9	PAN HEAD SCREW #8 - 1 1/2" / VIS PAN #8 - 1 1/2"	6
10	PAN HEAD SCREW #8 - 3/8" / VIS PAN #8 - 3/8"	1
11	CENTER GUIDE / GUIDE CENTRAL	1
12	SIDE GUIDE / GUIDE LATÉRAUX	2
13	BUMPER / BUTOIR	6
14	KEY / CLÉ	1
15	WALL PLUG / CHEVILLE	7

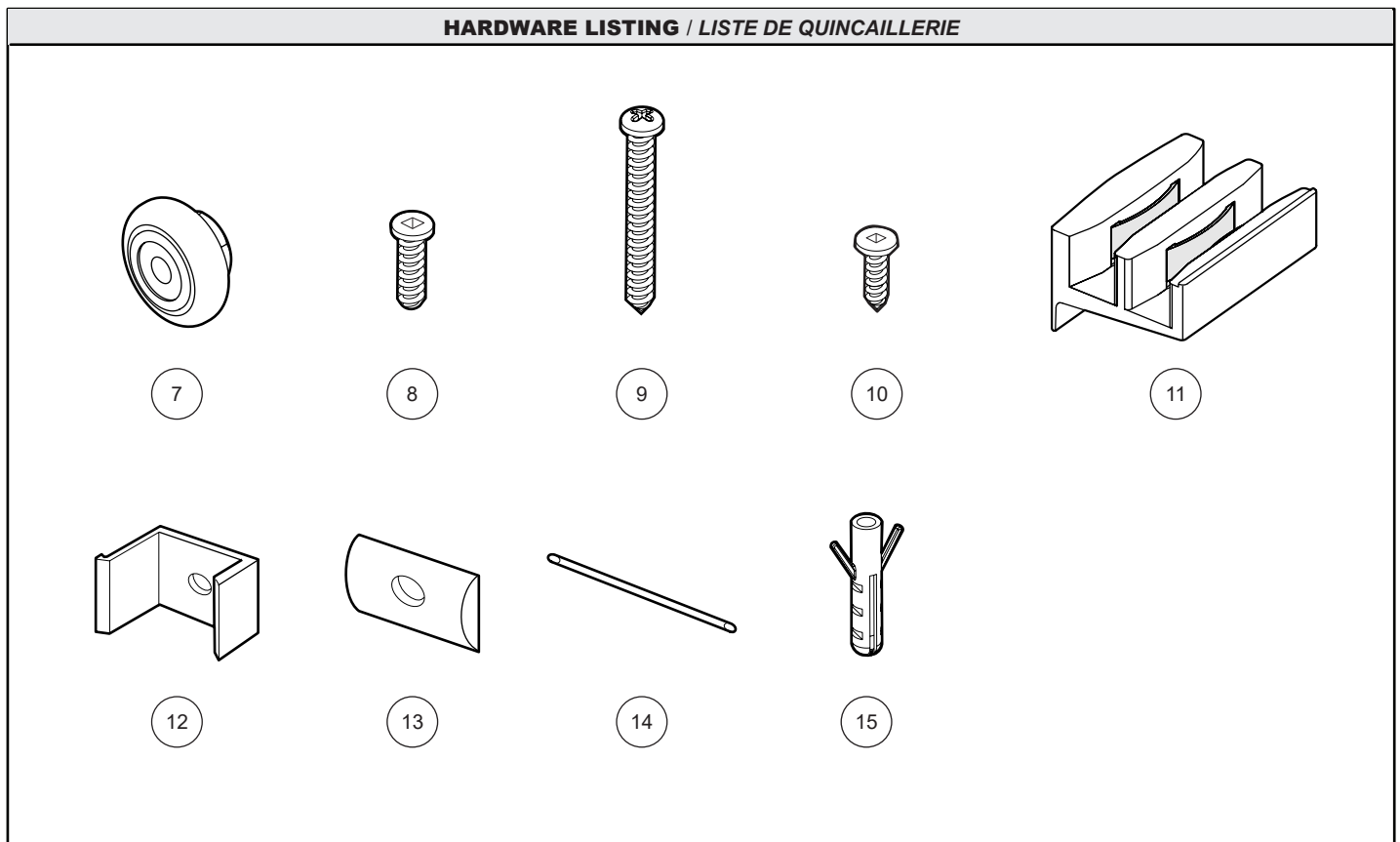

1

CUT BOTTOM TRACK / COUPER LE RAIL INFÉRIEUR

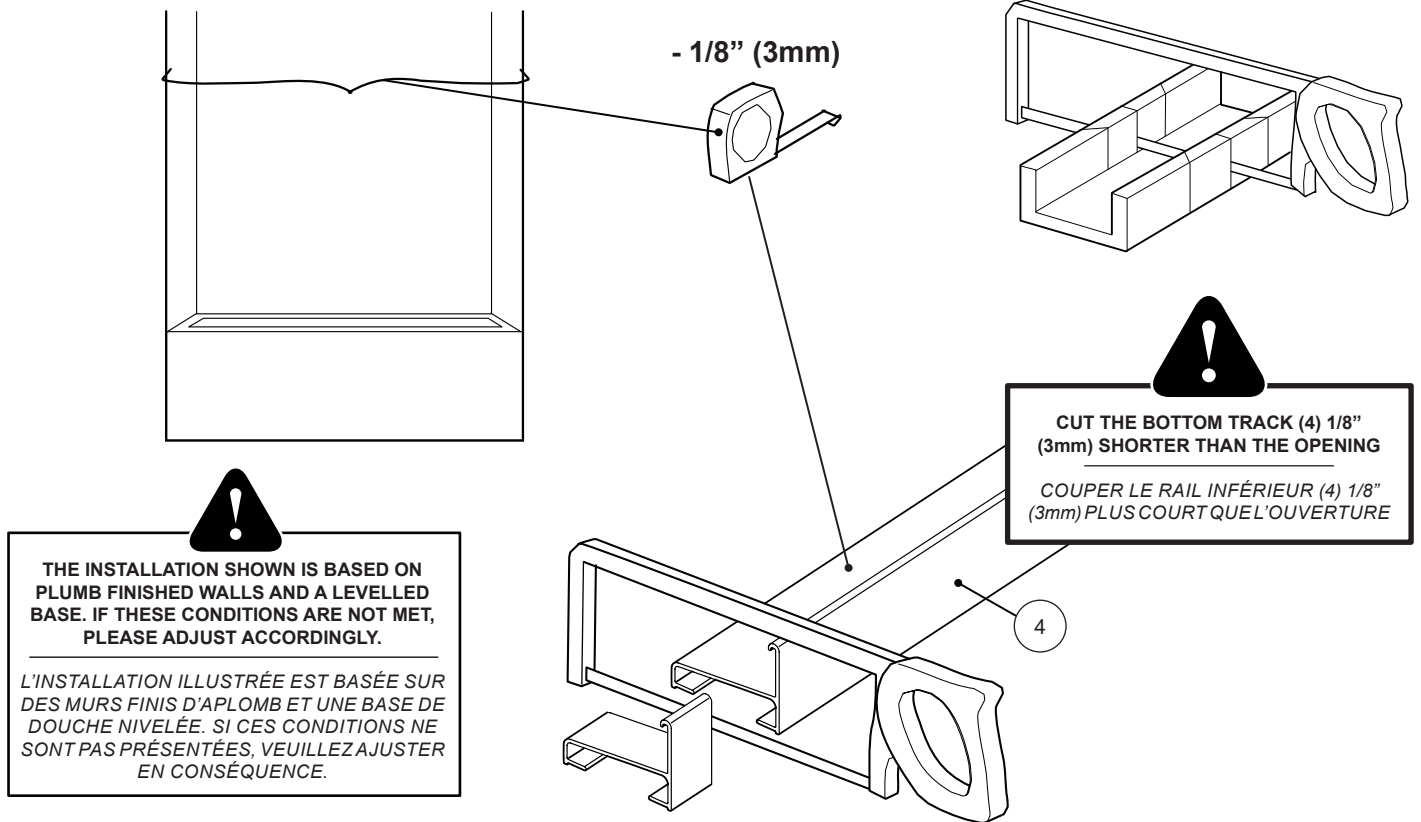

2

INSTALL BOTTOM GUIDE TO BOTTOM TRACK / INSTALLER LE GUIDE DU BAS SUR LA RAIL INFÉRIEUR

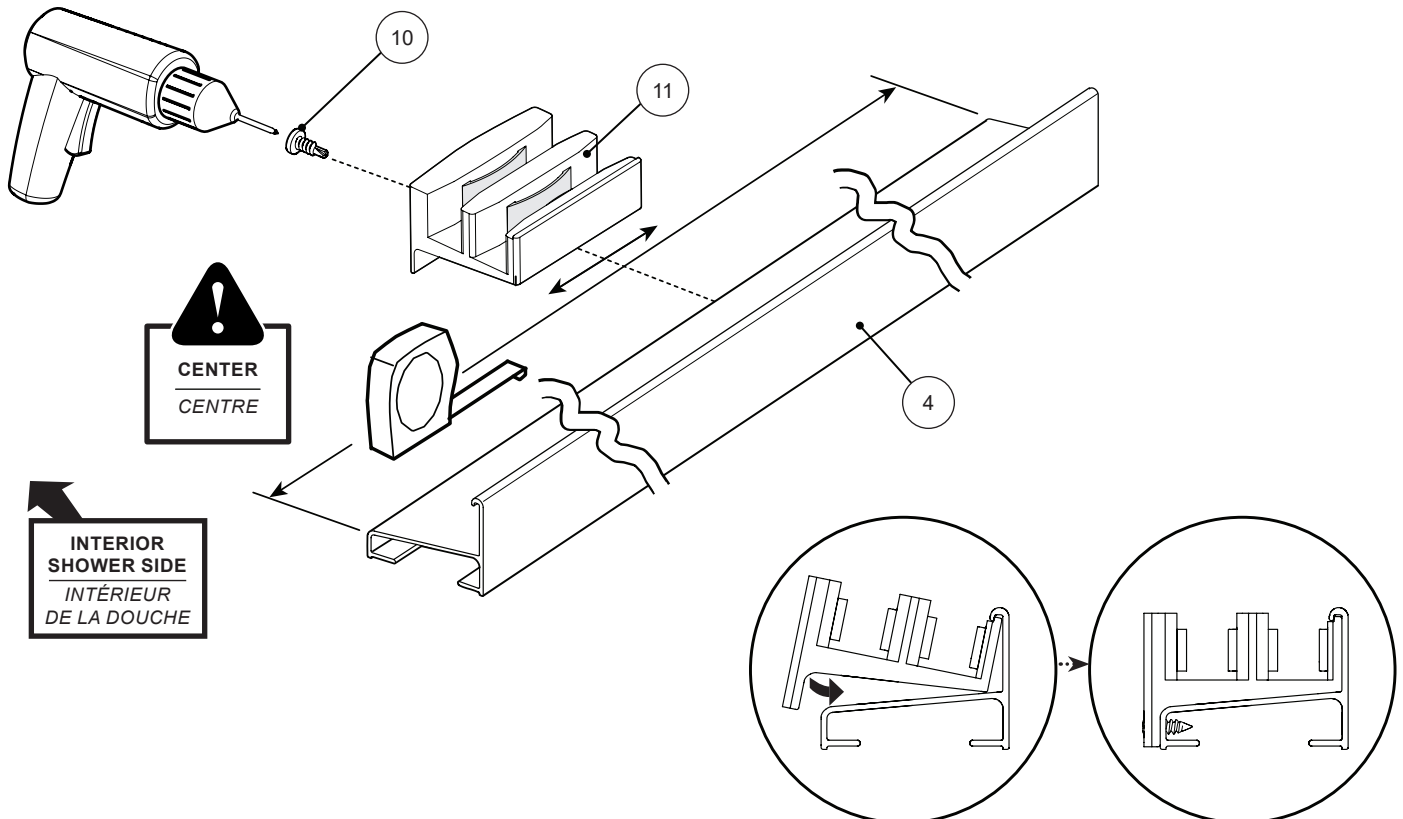



Wipe the base with a clean cloth before installing the bottom track.
Essuyer la base avec un chiffon propre avant d'installer le rail inférieur.

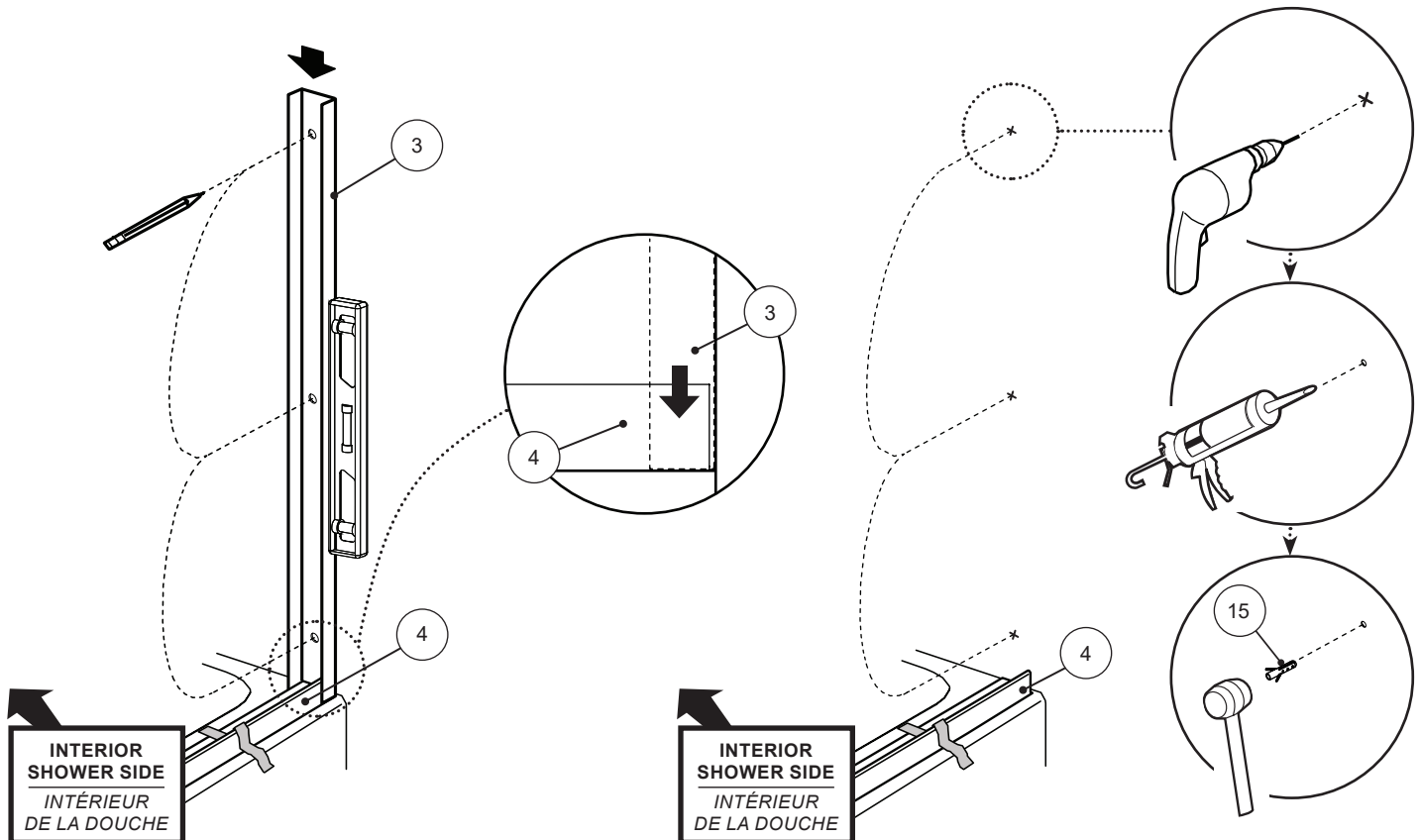
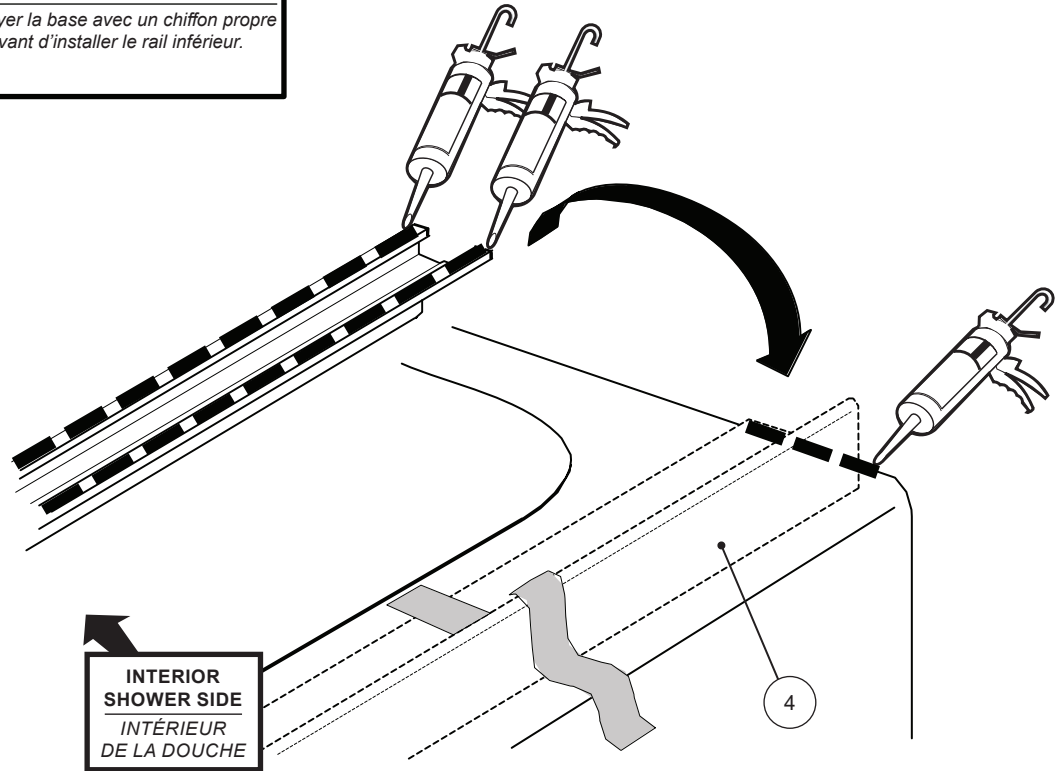

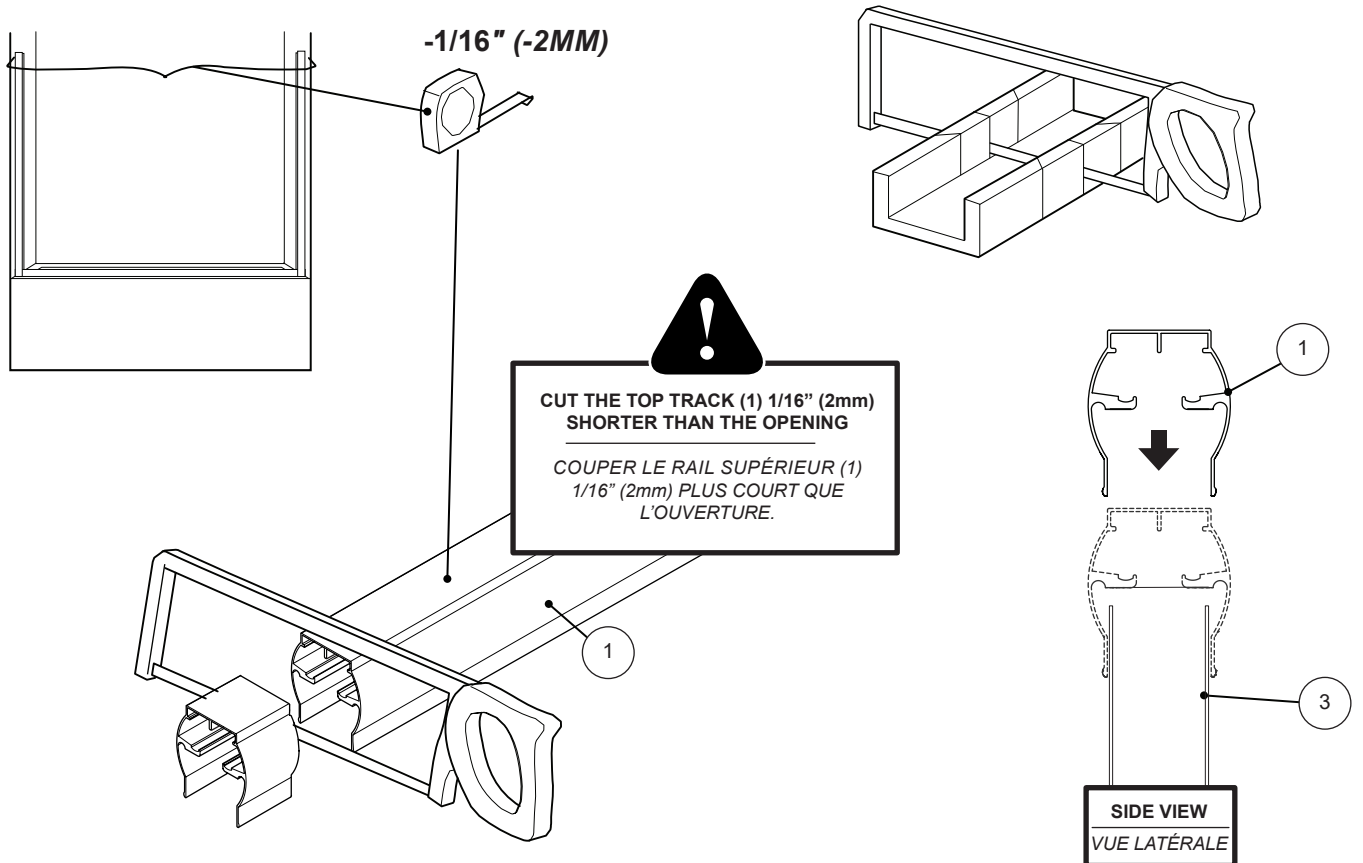
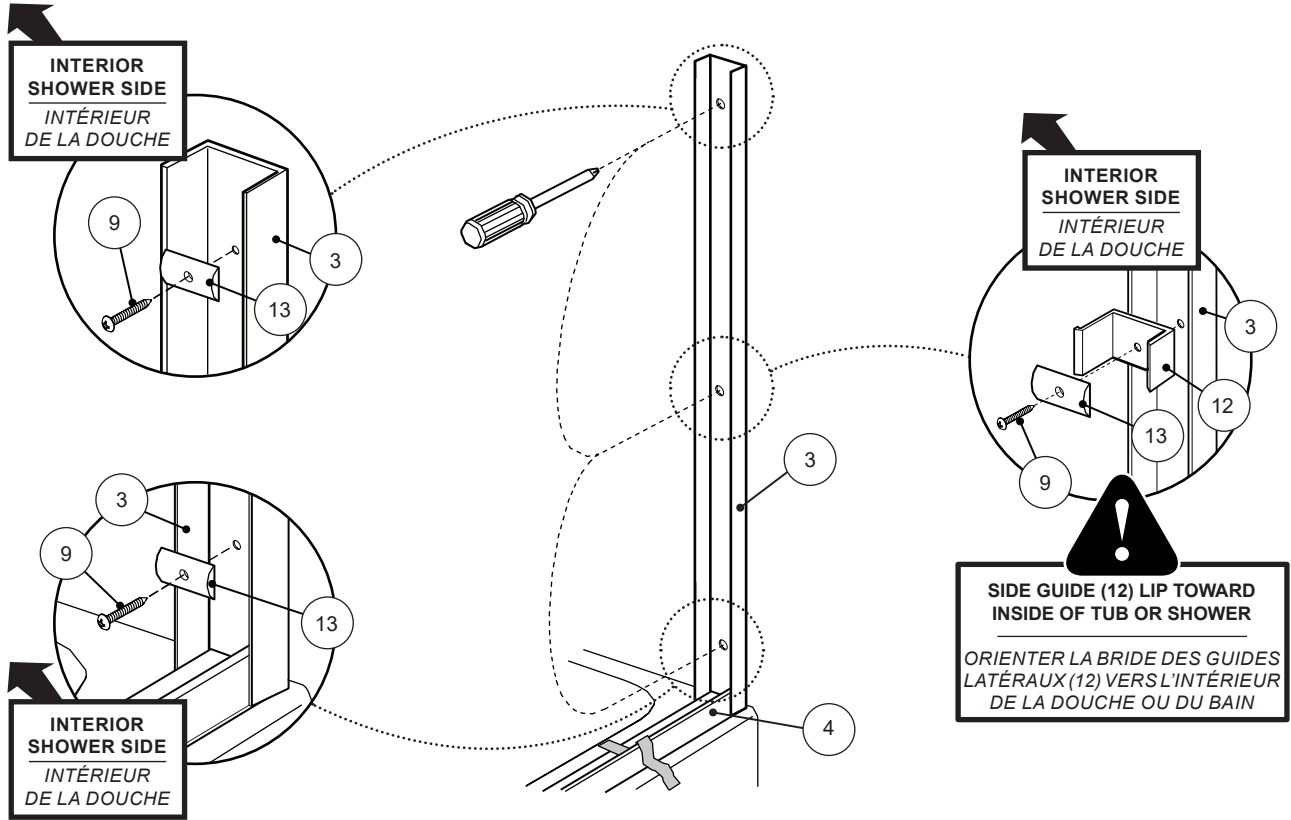

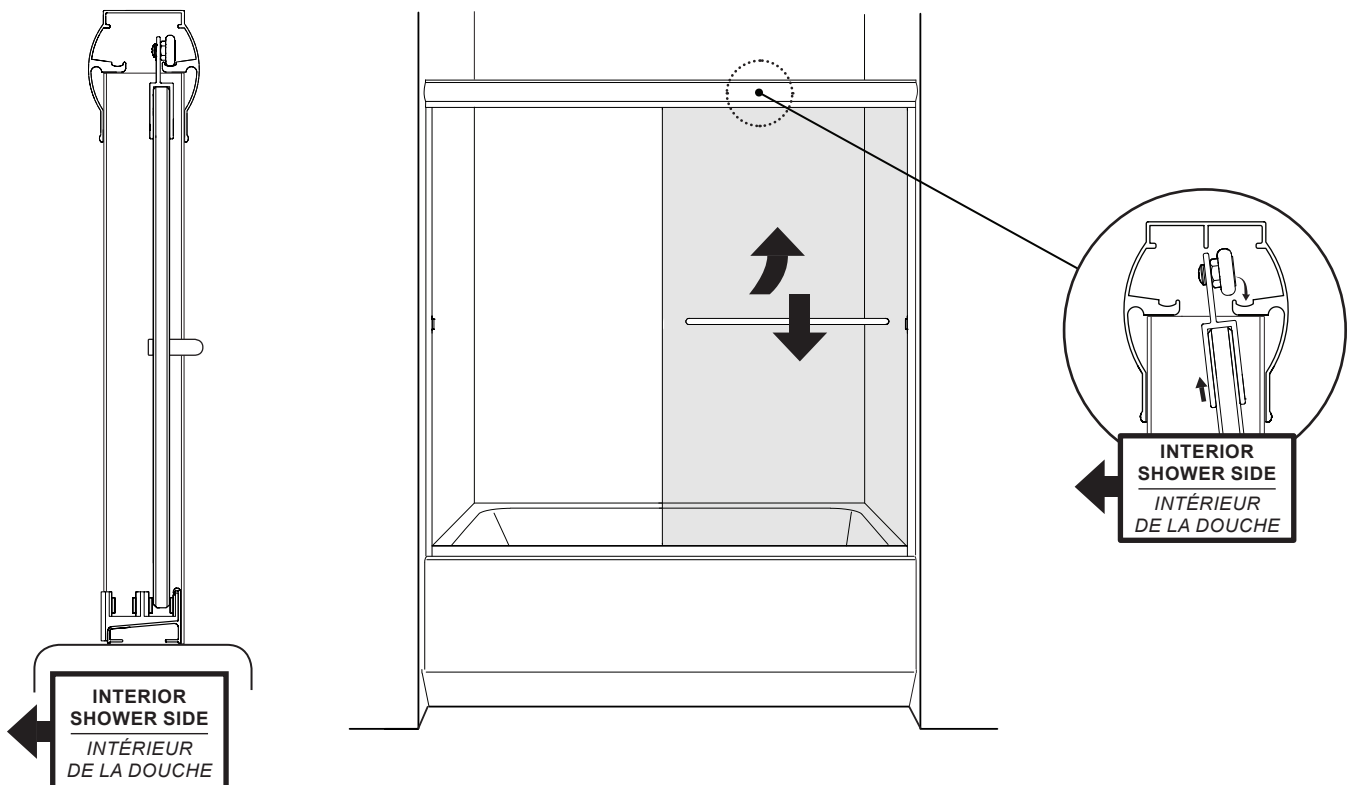
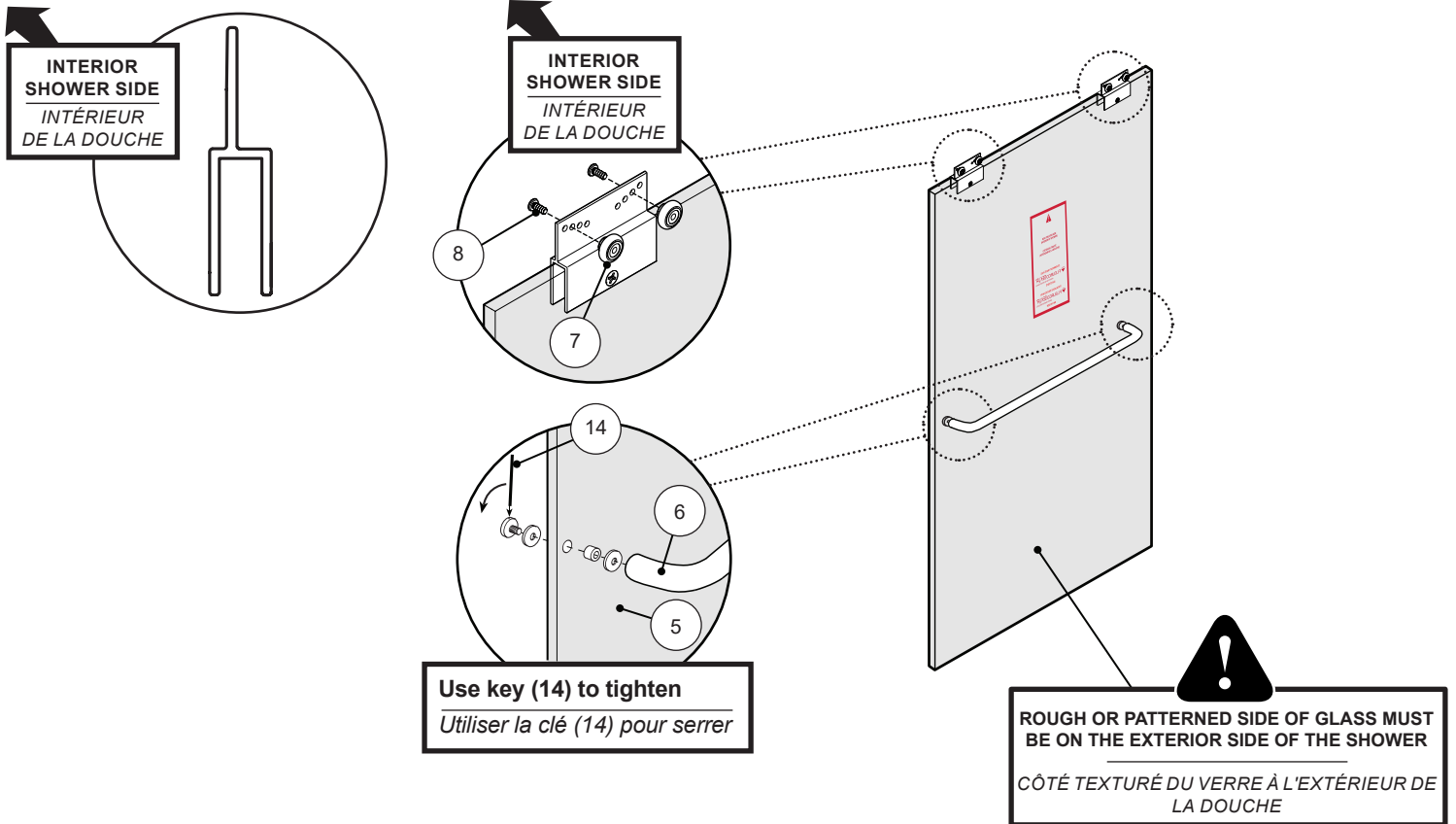

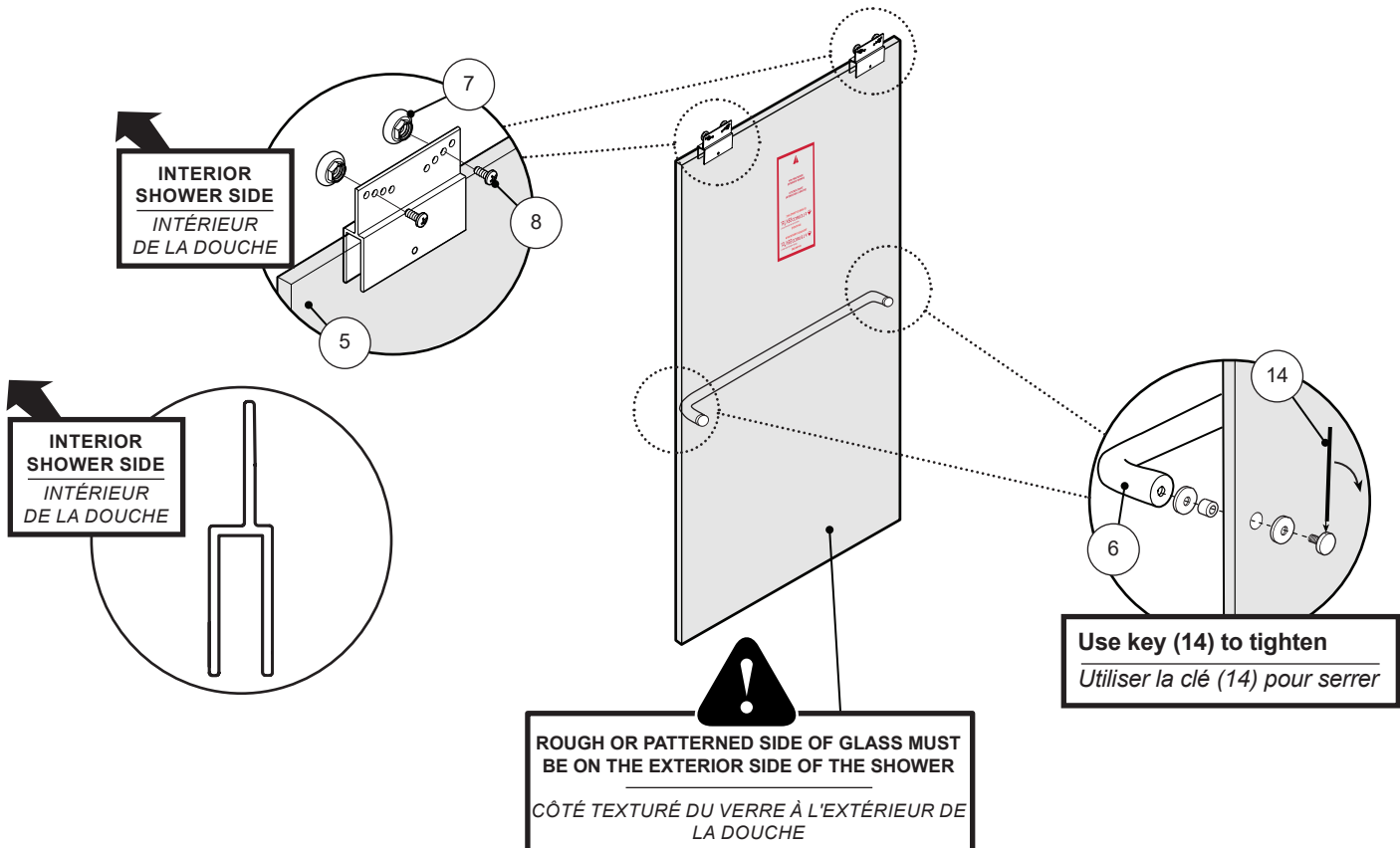
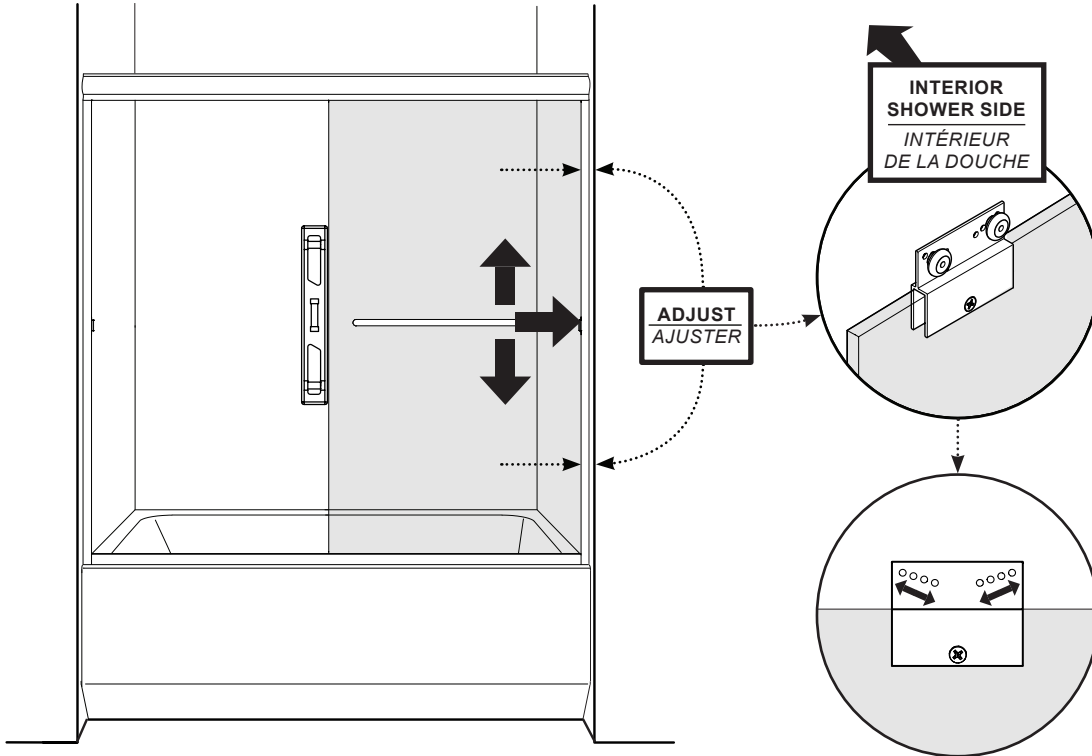

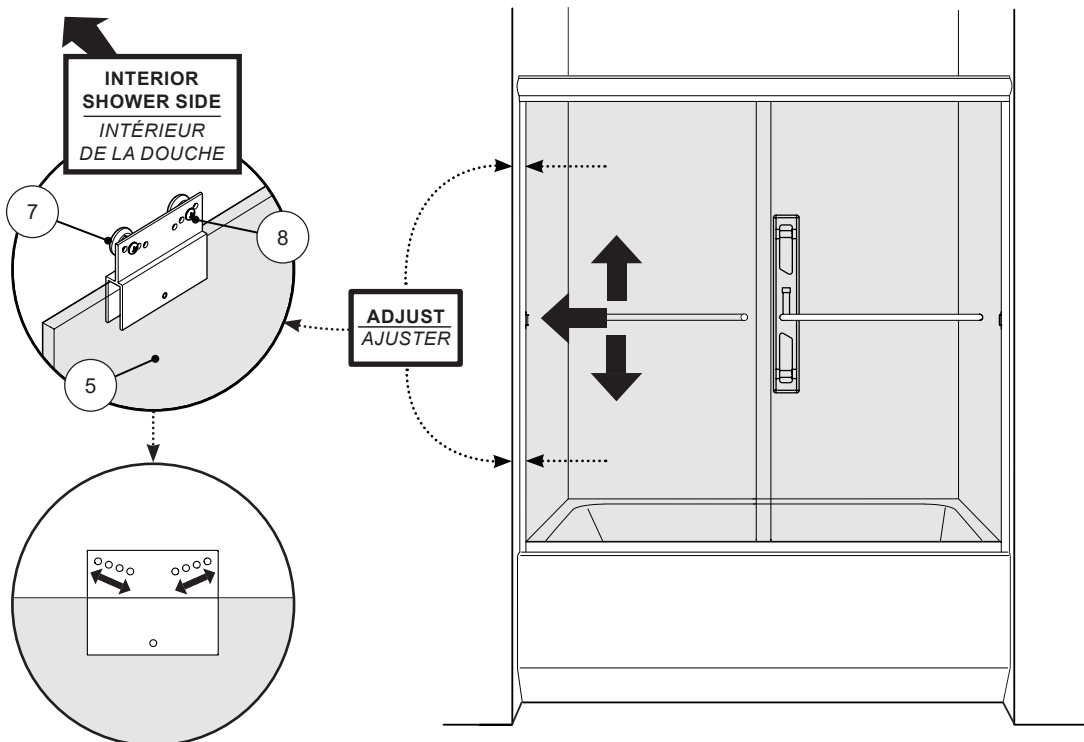
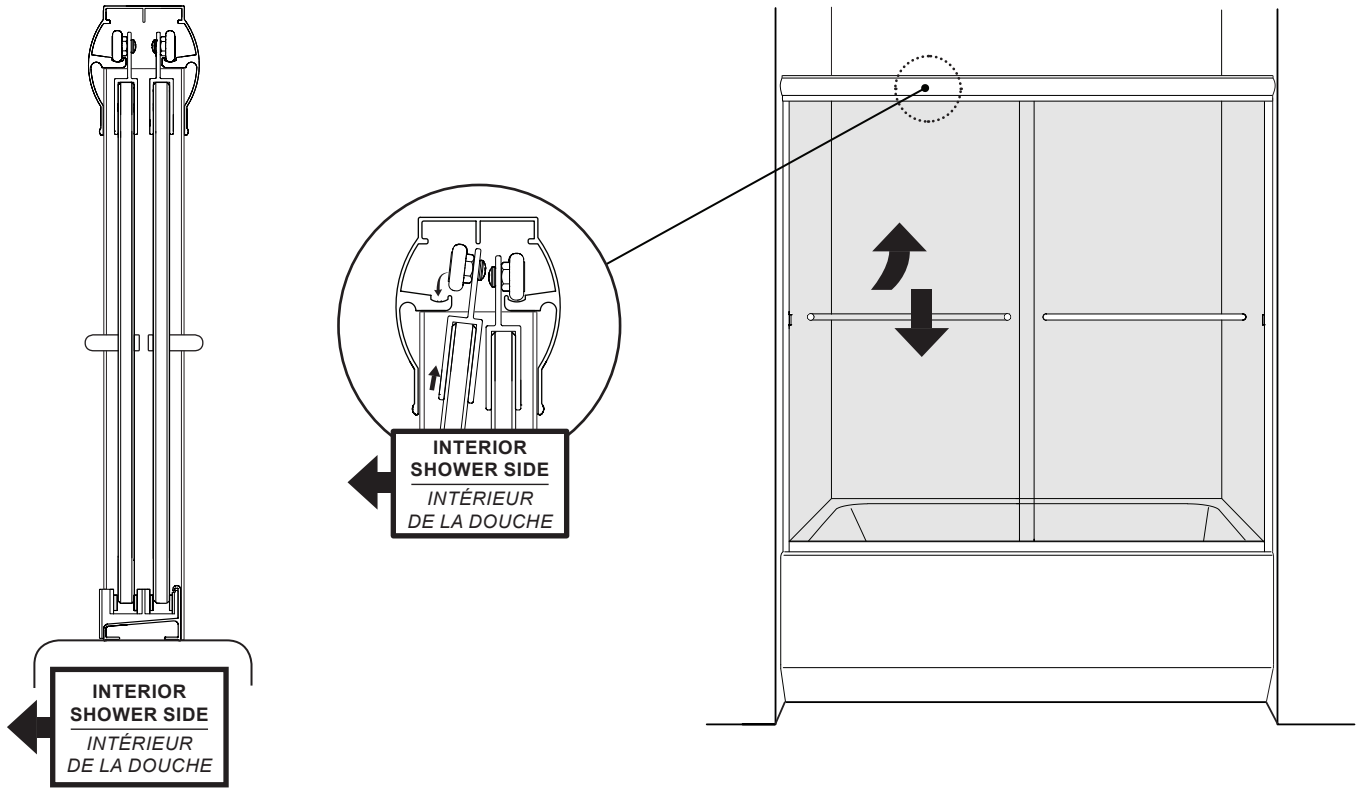

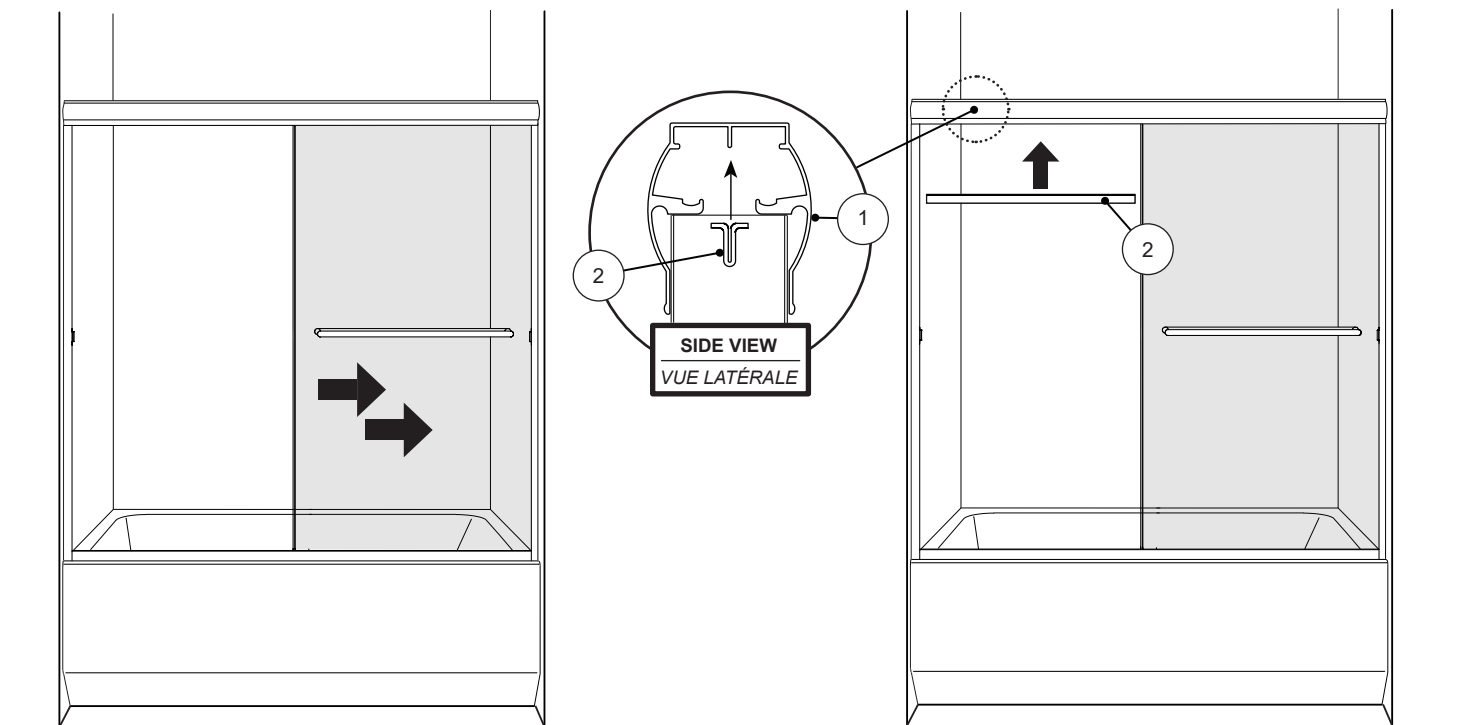
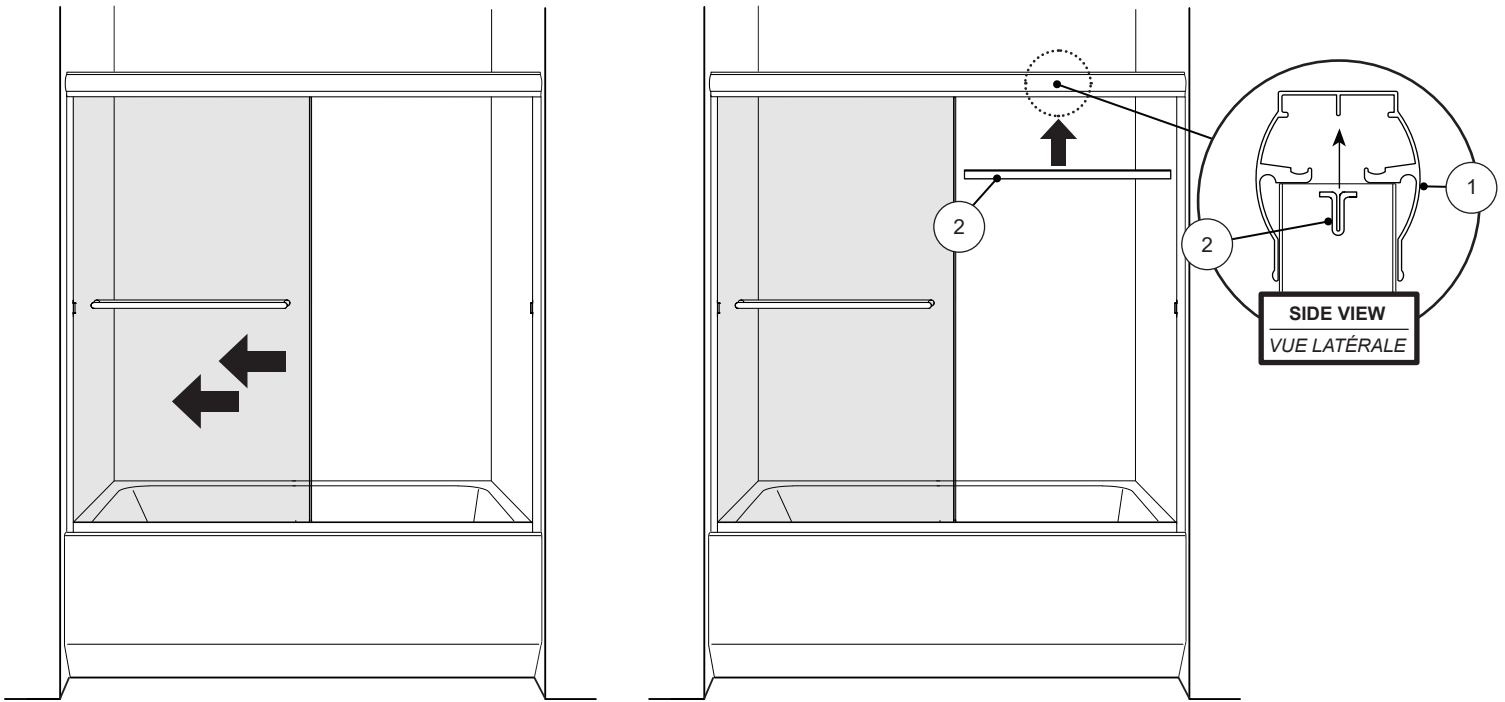

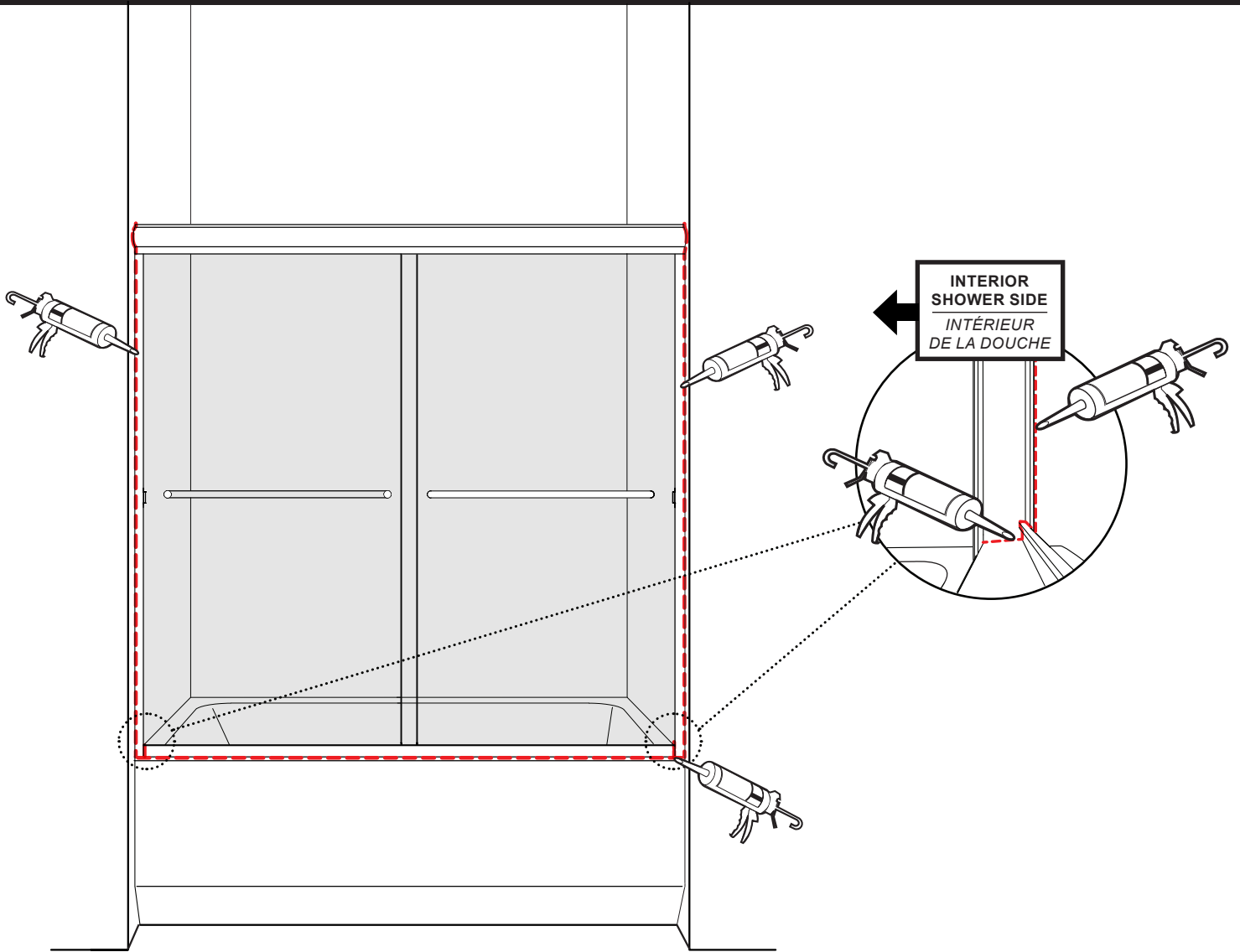

24 HOURS
HEURES